

RENAISSANCE Wall Mixer Code 59100



INSTALLATION

Warranty may become void if the installation procedures are not carried out as follows: -

- A pressure limiting device must be fitted if pressure exceeds 500kPa – refer AS/NZS 3500.1:2003 (Clause 3.34)
 - Prior to installation, the system must be flushed out thoroughly to remove all foreign matter
 - Water temperature must not exceed 75°C
 - The cartridge locking nut (under the lever) has been factory pre-set to a set force. This must not be removed without prior authority from Alder Tapware.
 - Removal of flow regulators from any outlet (spout or shower) connected to this wall mixer
 - If the flow rate reduces on this wall mixer, check the aerator filter of the outlet connected to ensure debris is not blocking the flow
1. Refer to the diagram below to show the maximum and minimum protrusion of the mixer in the wall to allow adequate finishing surface for tiles or the material
 2. Ensure the plastic protective cover is pushed onto the mixer body as far as possible before installation. This cover protects the finish of the product during installation.
 3. The mixer plastic dome protective cover is held in place with a screw that goes through to the cartridge spigot
 4. The protective cover should not be removed, until after the tiling services are complete
 5. When the trim kit install is required, remove the plastic protective cover off the wall mixer body and replace the screw into the end of the cartridge spigot
 6. *Ensure that this screw is retained as it is required for correct spacing when fitting the lever.*
 7. Fit the wall back plate – apply some silicon sealant to rear of back plate.
 8. Fit lever onto the spigot – hole of the grub screw faces the top
 9. Using the Allen key tighten the grub screw to ensure tight fit with the spigot
 10. Fit the chrome button to cover the grub screw hole

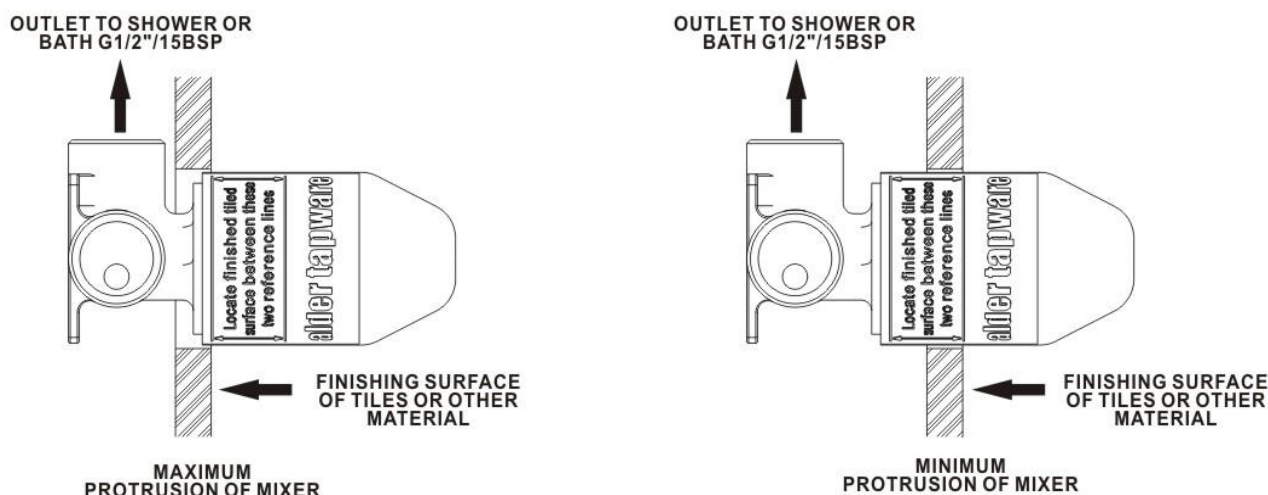

WARRANTY

- Full details of our warranty terms and conditions can be found on our website.

For all servicing needs, please contact CUSTOMER SERVICE on:

FREECALL: 1800 800 919

PHONE: 08 6217 0600

FAX: 08 6217 0699

EMAIL: customer.service@aldertapware.com.au

www.aldertapware.com.au

V01 200128 - Page. 1